

Atkinson Dynamics Intercom

Model AD-28X-MV

Installation and Service Instructions



ATKINSON DYNAMICS

A FEDERAL SIGNAL COMPANY
2645 Federal Signal Drive
University Park, IL 60484-3167
(888) 751-1500

INSTALLATION AND SERVICE INSTRUCTIONS FOR MODEL AD-28X-MV



SAFETY MESSAGE TO INSTALLERS, USERS AND MAINTENANCE PERSONNEL

It is important to follow all instructions shipped with this product. This device is to be installed by a trained electrician who is thoroughly familiar with the National Electrical Code and will follow NEC Guidelines as well as local codes. Marine installations shall be in accordance with Title 46, CFR, Parts 110-113.

The selection of the mounting location for the device, its controls and the routing of the wiring is to be accomplished under the direction of the facilities engineer and the safety engineer. In addition, listed below are some other important safety instructions and precautions you should follow:

- This is not a Listed emergency safety device and is not intended to be used as such.
- Read and understand all instructions before installing or operating this equipment.
- Disconnect power before connecting or doing any maintenance on this intercom.
- All effective warning speakers produce loud sounds which may cause in certain situations, permanent hearing loss. You should take appropriate precautions such as wearing hearing protection.
- After testing is complete, provide a copy of this instruction sheet to all operating personnel.
- Establish a procedure to routinely check the intercom installation for integrity and proper operation. Any maintenance must be performed by a trained electrician in accordance with NEC guidelines and local codes.

Failure to follow all safety precautions and instructions may result in property damage, serious injury, or death to you or others.

A. General Features.

The AD-28X-MV intercom is a heavy duty, 2-way, communications device designed for industrial applications. Nominal operating voltages include 120/240VAC, 50/60Hz and 24VDC. Voltage changes for the 120/240VAC are internally switch selectable and the AC line is fused with a 1/2 amp 250 volt type GMC fuse. The unit also offers transformer isolated audio inputs and internally selectable Master or Slave mode configurations. A call button with remote call dry contacts is also factory supplied in the unit.

The AD-28X-MV has a Type 4X enclosure and is a UL Listed Type NM (non-monitored) signal appliance and Marine signal appliance for indoor or outdoor use and is CSA Certified. The AD-28X-MV is additionally Listed for Class I, Groups A, B, C and D, Division 2; Class II, Groups F and G, Division 2; and Class III.

Wire all circuits connected to the AD-28X-MV Intercom using Class I, Division 2 wiring methods specified in Article 501-4 (b) of the NEC.

MASTER MODE:

The intercom can be configured as a Master unit (Push-to-Talk) or a Slave unit (Push-to-Listen) by changing the MAS/SLA jumper (J2) on the printed circuit board (see Figure 6). The intercom comes from the factory set in the Master (MAS) mode.

In the Master mode the intercom acts as an amplifier, constantly broadcasting over its speaker any signal that it receives on the signal lines. Holding down the Listen/Talk switch changes the unit from a speaker to a microphone (see Figure 1). The intercom will now transmit over the signal lines to additional intercom(s) also set in the Master mode. When the switch is released it will default back to the Listen or Speaker mode, allowing the user to receive any messages transmitted back to it.

SLAVE MODE:

Some applications may require that the intercom constantly transmit (i.e. act as a microphone) as opposed to constantly receive (i.e. act as a speaker). To accomplish this the intercom must be configured in the Slave (Push-to-Listen) mode.

To configure an intercom in the Slave mode, perform the following steps:



Disconnect power to the intercom before any installation, maintenance, or configuration changes are performed.

1. Move the J2 jumper on the P.C. board from the MAS to SLA position (see Figure 6). This can be done using long nose pliers, pulling the jumper off the “MAS” and center position and placing it on the “SLA” and center position.
2. An intercom configured in the Slave mode needs to have the Listen/Talk switch default to the talk position on the cover plate (see Figure 2).

The second change required is to rotate the position of the Talk/Listen switch. This can be accomplished by loosening the rubber boot covering the toggle switch enough to allow the toggle switch to turn 180 degrees. The dimple on the locking ring must seat itself in the locating hole (see Figure 3). The rubber boot is then tightened up against the cover plate with the toggle switch leaning to the talk position, as shown in Figure 2.

3. The third change involves the interconnect wiring. When a unit is placed in the Slave mode it defaults to the Talk or transmit position. When hooked to a Master unit it is necessary to override the Slave unit in order for the Master unit to be able to transmit. The #6 pin (remote control) on both terminal blocks (see Figure 4) must be connected between the Master and the Slave unit. Figures 7 to 13 contain wiring diagrams of typical intercom configurations.

REMOTE CONTROL:

Remote control is used to change the operation mode of a remote intercom from listen to talk or from talk to listen upon activation of a local intercom. The wiring diagram section illustrates Master/Slave Installation and Using Foot Switches Diagrams. (See figures 9, 10, and 12).

Normally open foot switches can also be connected to the Remote Control line in order to allow “hands free” operation of the listen/talk functions.

CALL BUTTON:

Depressing the call button sends a 1 kHz tone onto the signal lines. All units listening to the line will then broadcast this signal as a call.



The call signal is substantially louder than normal voice messages being carried on the line. Do not depress the call switch while carrying on a conversation with someone on the system. This will subject the listener to very loud sound levels.

The volume of the call signal is affected by the volume control on the receiving unit, so if the volume is turned all the way down at a receiving station, the call signal will not be heard. To avoid this problem, the call dry contacts can be utilized to drive an external signalling device.

CALL BUTTON ACTUATED DRY CONTACTS FOR OPERATING AN EXTERNAL DEVICE:

Depressing the call button also closes a normally open dry contact rated at 0.5 A at 125 Vac or 1.25 A at 24 Vdc. This contact can be used to trigger a remote sounder or light in order to accent the call feature. The wiring diagram illustrates how an external light or horn can be wired in to augment the call tone. (See Figure 11.)

24 Vdc:

When connecting the intercom to 24 Vdc, either the positive (+) supply conductor must be fused at the source with a 1/2 A fuse or a power-limited power source must be used.

The AD-28X-MV is capable of sending DC power to another unit which is mounted in a remote location without local power. 24 Vdc is available from pins 4 and 5 of the terminal block. It can be run along with the signal lines to an intercom in a remote location. Only one unit should share the power supply of another unit in any installation.

NOTE

Connect positive (+) supply conductor to pin #4 of terminal block. Connect negative (-) supply connector to pin #5 of terminal block.

Figure 7 in the wiring diagrams section shows how two intercoms can be hooked up if no remote power is available.

SURGE PROTECTION:

Metal Oxide Varistor (MOV) devices are used to protect the audio lines and the remote control line. The intercom must have Earth Ground terminated to it to ensure surge protection.

The output amplifier of the AD-28X-MV offers full short circuit protection and overheat protection.

MODEL AD-28X-MV SPECIFICATIONS

| Operating Voltage | 24Vdc, 120 Vac and 240 Vac 50/60 Hz | | | | | | | | | | | | |
|---|--|---------|-----------|---------|--------|--------|-------|---------|--------|-------|---------|-------|-------|
| Current Draw | <table><thead><tr><th>Voltage</th><th>Operating</th><th>Standby</th></tr></thead><tbody><tr><td>24 Vdc</td><td>260 mA</td><td>62 mA</td></tr><tr><td>120 Vac</td><td>163 mA</td><td>70 mA</td></tr><tr><td>240 Vac</td><td>82 mA</td><td>35 mA</td></tr></tbody></table> | Voltage | Operating | Standby | 24 Vdc | 260 mA | 62 mA | 120 Vac | 163 mA | 70 mA | 240 Vac | 82 mA | 35 mA |
| Voltage | Operating | Standby | | | | | | | | | | | |
| 24 Vdc | 260 mA | 62 mA | | | | | | | | | | | |
| 120 Vac | 163 mA | 70 mA | | | | | | | | | | | |
| 240 Vac | 82 mA | 35 mA | | | | | | | | | | | |
| Amplifier Specifications | | | | | | | | | | | | | |
| Frequency Response (-6dB) | 150 Hz to 12 kHz | | | | | | | | | | | | |
| Input Impedance | 3400 ohms | | | | | | | | | | | | |
| Max. Output Voltage | | | | | | | | | | | | | |
| Sine Wave: | | | | | | | | | | | | | |
| Unbalanced Output | 7.5 Vrms | | | | | | | | | | | | |
| Square Wave: | | | | | | | | | | | | | |
| Unbalanced Output | 9.5 Vrms | | | | | | | | | | | | |
| Speaker Rating | 30 watts | | | | | | | | | | | | |
| Speaker Impedance | 16 ohms | | | | | | | | | | | | |
| Temperature Range for Ordinary Locations | -31° F to +150° F (-35° C to +66° C) | | | | | | | | | | | | |
| Temperature Range for Hazardous Locations | +41° F to +149° F (+5° C to +65° C) | | | | | | | | | | | | |
| Fuse Type GMC-1/2 | 1/2 A, 250 V | | | | | | | | | | | | |
| Call Button Actuated Dry Contact Rating | 500 mA at 125 Vac 1.25 A @ 24 Vdc | | | | | | | | | | | | |
| Weight | | | | | | | | | | | | | |
| Shipping | 10 lb, 11 oz | | | | | | | | | | | | |
| Net | 9 lb, 4 oz | | | | | | | | | | | | |
| Housing Dimensions | 6.5" (16.5 cm) W x 9.88" (25.1 cm) H x 3.88" (9.9 cm) D | | | | | | | | | | | | |
| Conduit Entrances | Dual 1/2"-14 IPS | | | | | | | | | | | | |
| Housing Material | Aluminum | | | | | | | | | | | | |
| Color | Gray | | | | | | | | | | | | |

Agency Listings
AD-28X-MV

UL (UJPX), (UJPX7), (UXPL, Marine) -
For indoor or outdoor use in Class I, Groups
A, B, C and D, Division 2; Class II, Groups
F and G, Division 2; Class III hazardous
locations; Type 4X enclosure.

T-Code at Maximum Ambient Temperature, °C

| Hazardous Location | 40° C | 65° C |
|--|--------------|--------------|
| Class I, Division 2, Groups A, B, C, D | T6 | T5 |
| Class II, Division 2, Groups F, G | T6 | T5 |
| Class III | T6 | T5 |



**EXPLOSION HAZARD – SUBSTITUTION OF COMPONENTS MAY IMPAIR
SUITABILITY FOR CLASS I, DIVISION 2.**

B. Unpacking.

After unpacking the Model AD-28X-MV, examine it for damage that may have occurred in transit. If the equipment has been damaged, do not attempt to install or operate it, file a claim immediately with the carrier stating the extent of the damage. Carefully check all envelopes, shipping labels and tags before removing or destroying them.

Before attempting to install the intercom, be sure that all parts listed in the KIT CONTENTS LIST have been supplied.

C. Kit Contents List.

| Qty. | Description | Part Number |
|-------------|-----------------------|--------------------|
| 1 | Wiring Block | 140A326-01 |
| 4 | Screws, Phillips Head | 7000478-10 |
| 4 | Lockwashers | 7074A010 |
| 1 | Resistor, 1K, 1W | 101216 |

D. Mounting.



The selection of the mounting location for the device, its controls and the routing of the wiring is to be accomplished under the direction of the facilities and the safety engineer.

The intercom is intended to be mounted on any relatively flat and rigid surface by the two mounting ears on the exterior of the housing. Figure 5 is a dimensional outline drawing showing the proper mounting configuration. The two mounting ears have slots for 3/8" (M10) bolts spaced 5-5/8" to 5-7/8" (14.3 cm to 14.9 cm) apart. Hardware for mounting the intercom to the surface is left up to the installer.



This unit is heavy and should be mounted on a rigid surface capable of supporting the weight of the intercom.

The intercom housing has two 1/2"-14 IPS openings in the bottom. When installing the conduit to these openings, seal the threads with pipe compound or other sealing material.



For shipboard applications, installations shall be in accordance with the United States Coast Guard, Title 46 CFR, Parts 110-113.

E. Electrical Connections.



Do not connect wires when power is applied.

All wiring to the intercom is terminated to the terminal block provided. The terminal block plugs into a header on the PC board and is configured such that it can only plug in one way. Figure 6 shows the orientation of the wiring block and describes the function of each position.

There is one jumper shown on the PC board in Figure 6 that may need to be moved depending on the desired operation of the intercom. J2 is for configuring the intercom as either a Master or Slave device. The intercom is factory set in the Master position.

There is a switch on the board to configure the operation of the board from 120VAC to 240VAC. The switch is factory set for the intercom to operate on 120VAC (see Figure 6).

See figures 7 through 13 for typical intercom configurations.



The Model AD-28X-MV's circuits are not nonincendive field wiring circuits except for foot switches. Wire all circuits connected to the AD-28X-MV Intercom using Class I, Division 2 wiring methods specified in Article 501-4 (b) of the NEC.

F. Service.



Any maintenance must be performed by a trained electrician in accordance with NEC guidelines and local codes.

1. General.



The call signal is substantially louder than normal voice messages being carried on the line. Do not depress the call switch while carrying on a conversation with someone on the system. This will subject the listener to very loud sound levels.

Atkinson Dynamics will service your equipment or provide technical assistance with any problems that cannot be handled locally.

Any units returned to Atkinson Dynamics for service, inspection, or repair must be accompanied by a Return Material Authorization. This R.M.A can be obtained only from the factory by calling (888) 751-1500.

At this time a brief explanation of the service requested or the nature of the malfunction, should be given.

Address all communications and shipments to:

ATKINSON DYNAMICS
Service Department
2645 Federal Signal Drive
University Park, IL 60484-3167

2. Replacement Parts.



Replace fuse with GMC-1/2 only. DO NOT substitute.

| Description | Part Number |
|---------------------------------------|-------------|
| PC Board, AD-28X-MV | K2001915-02 |
| Kit, potentiometer with on/off switch | K8590236 |
| Kit, toggle switch | K8590298 |
| Kit, push button switch | K8590241 |
| Knob, Pot | K141A129 |
| Rubber Boot (Toggle Switch) | K288801 |
| Rubber Boot (Pushbutton Switch) | K288697 |
| Rubber Boot (Volume Control) | K288A542A |
| Terminal Block | K140A326-01 |
| AD-28X-MV Speaker/Housing Assy. | K8590217 |
| Cover Gasket | K8590013 |
| Resistor, 1K, 1W | K101216 |
| Fuse, GMC-1/2 | K148A155 |
| Mini-jumpers | K139A209 |

1

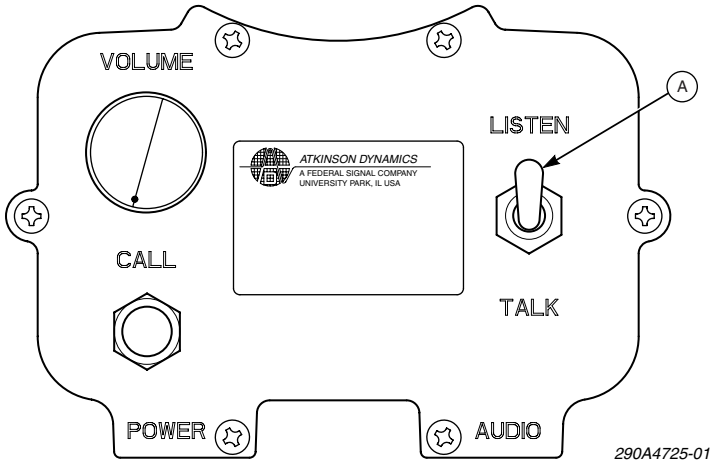

290A4725-01

English

A. Push down to talk

2

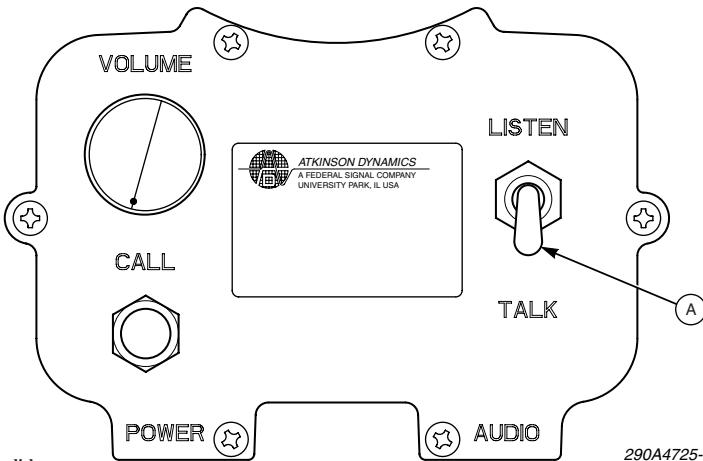

290A4725-02

English

A. Push up to listen

3

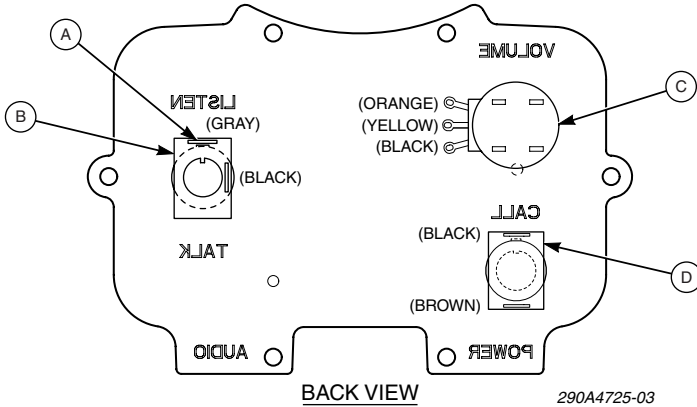

English

- A. Dimple
- B. Listen/talk toggle switch

- C. Volume control
- D. Call push button

4

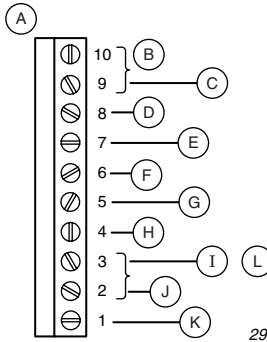

English

- | | |
|--------------------------|---------------------|
| A. Terminal block pinout | G. Ground |
| B. Dry contact | H. 24VDC in/out (+) |
| C. For call | I. Neutral |
| D. Audio (-) | J. Hot |
| E. Audio (+) | K. Earth ground |
| F. Remote control | L. 120/240VAC in |

NOTE: Terminal Block accepts 10 - 22 AWG wire.

5

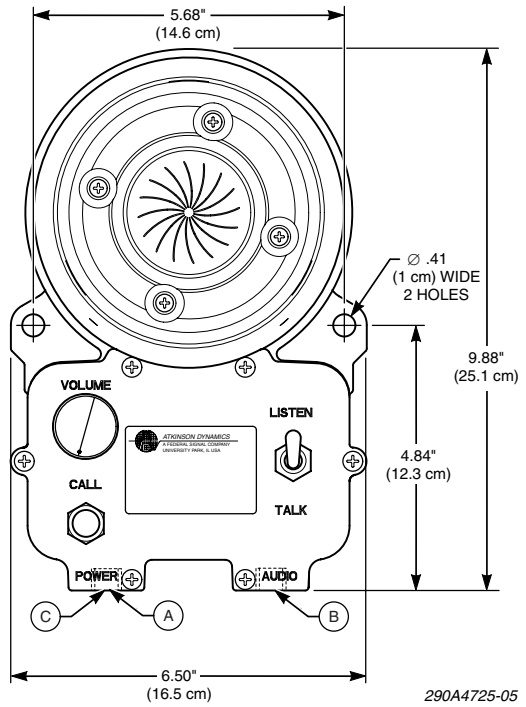
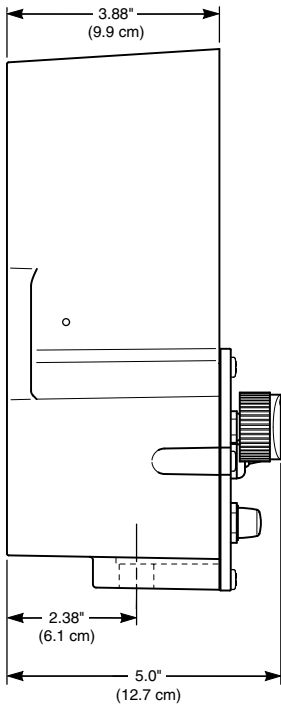

290A4725-05

English

- A. 1/2-14 pipe thread 2 places
- B. Audio (Class 2)
- C. AC input (Class 1) or DC Input/Output (Class 2)
Positive supply conductor must be fused at source with 1/2 A fuse or a power-limited source must be used.

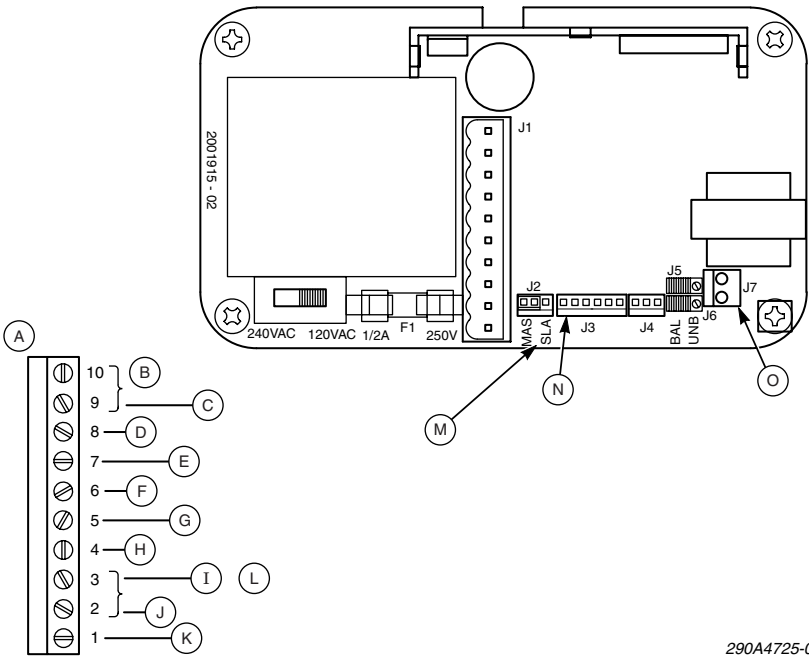

290A4725-06

English

- A. Terminal block pinout
- B. Dry contact
- C. For call
- D. Audio (-)
- E. Audio (+)
- F. Remote control
- G. Ground
- H. 24VDC in/out

- I. Neutral
- J. Hot
- K. Earth ground
- L. 120/240VAC-in
- M. Master slave
- N. To control panel
- O. Speaker plug

Operating Principle:

- When one talks, all intercoms will hear.
- To talk to other stations, press the talk/listen switch and speak into the speaker/microphone. Release talk switch to listen.

NOTES:

1. Speaker/Microphone
2. Off/On/Speaker Volume Control
3. Talk/Listen Switch
4. "Call" Tone Switch
5. 3-conductor/16-22 gauge cable. Use shielded cable in electrically noisy areas. Ground one end of the shield to "earth" ground. Ground chassis of DC unit to ground.

| Power | Remote A | Remote B |
|--------------|-----------|----------|
| 120V 50/60Hz | AD-28X-MV | -- |
| 22-30VDC | AD-28X-MV | AD-56-1 |
| 240V 50/60Hz | AD-28X-MV | -- |

POWER CONNECTIONS (Remote B):

| | | |
|-----|-----------|---------------|
| BLK | +DC Power | 12/24V Models |
| WHT | Common | 12/24V Models |

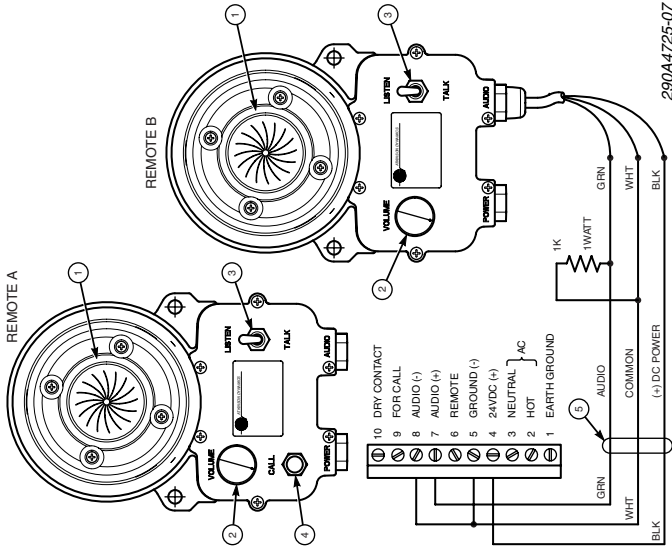
**Reminders:**

- Before installing remote intercoms, precautions should be taken to prevent feedback between two or more remotes in close proximity and acoustically reflective areas.
- 16-20 gauge low voltage audio cable. Twisted pair not required.
- Shielded audio cable not required unless operating in high electromagnetic fields. Ground one end of the shield to earth ground.
- Audio and power cables are not supplied with AD-28X-MV.

Operating Principle:

- When one talks, all intercoms will hear.
 - To talk to other stations, press the talk/listen switch and speak into the speaker/microphone.
- Release talk switch to listen.

NOTES:

1. Speaker/Microphone
2. Off/On/Speaker Volume Control
3. Talk/Listen Switch
4. "Call" Tone Switch

| Power | Remote A | Remote B |
|--------------|-----------|----------|
| 12-18VDC | -- | AD-26A |
| 120V 50/60Hz | AD-28X-MV | AD-27A |
| 22-30VDC | AD-28X-MV | AD-56A |
| 240V 50/60Hz | AD-28X-MV | AD-57A |

POWER CONNECTIONS (Remote B):

| | | |
|-----|--------------|----------------------|
| BLK | +DC Power | 12/24V Models |
| | HOT | 120/240V Models |
| WHT | Common | 12/24V Models |
| | Neutral | 120/240V Models |
| GRN | Earth Ground | 120/240V Models only |

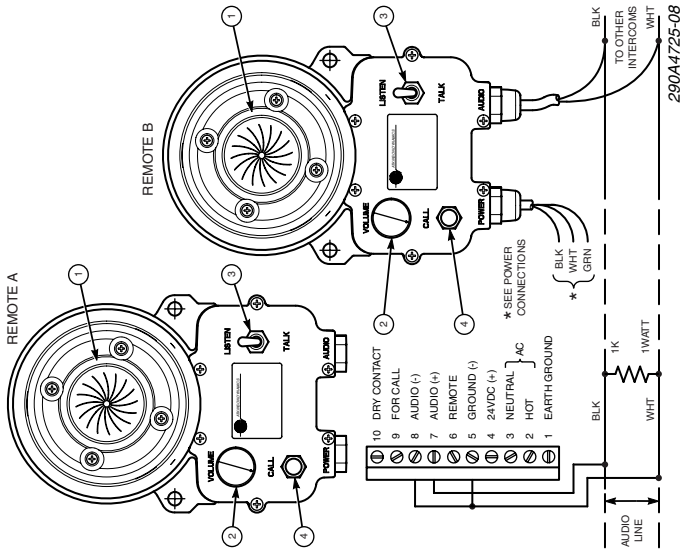

Reminders:

- Before installing remote intercoms, precautions should be taken to prevent feedback between two or more remotes in close proximity and acoustically reflective areas.
- 16-20 gauge low voltage audio cable. Twisted pair not required.
- Shielded audio cable not required unless operating in high electromagnetic fields. Ground one end of the shield to earth ground.
- Audio and power cables are not supplied with AD-28X-MV.

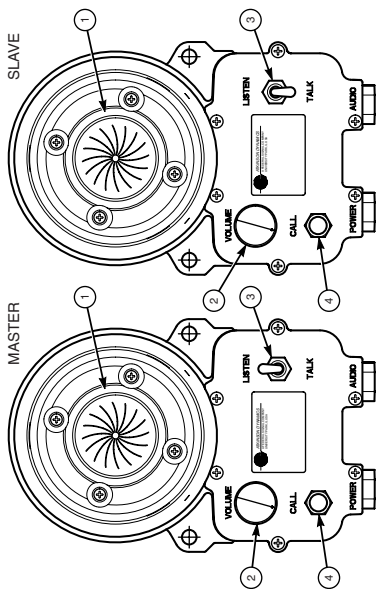

Operating Principle:

- Masters normally listen to slave.
- Slave talks to master hands-free, without having to press a talk switch.
- When any master talks, slave hears. Other masters will hear.
- To talk into master, press talk switch and speak into speaker/microphone. Release talk switch to listen.

NOTES:

1. Speaker/Microphone
2. Off/On/Speaker volume control
3. Press-to-talk Switch
4. "Call" Tone Switch

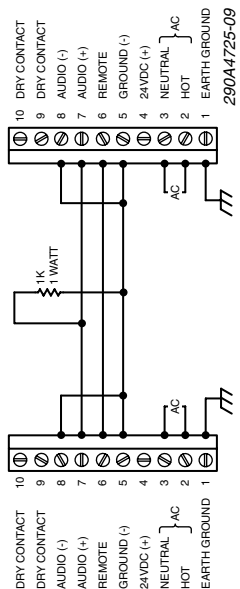

| Power | Master | Slave |
|--------------|-----------|-----------|
| 120V 50/60Hz | AD-28X-MV | AD-28X-MV |
| 22-30VDC | AD-28X-MV | AD-28X-MV |
| 240V 50/60Hz | AD-28X-MV | AD-28X-MV |

Reminders:

- Before installing remote intercoms, precautions should be taken to prevent feedback between two or more remotes in close proximity and acoustically reflective areas.
- Audio and power cables are not supplied with AD-28X-MV.
- In this installation the Master is constantly broadcasting audio from the Slave. Pushing the listen/talk switch on either unit forces the Slave into the listen mode and the Master into the talk mode. The MAS/SLA jumper J2, located on the P.C. board inside the Slave, must be placed in the SL-A mode for this operation. See SLAVE MODE on page 2 and figures 2 and 6.

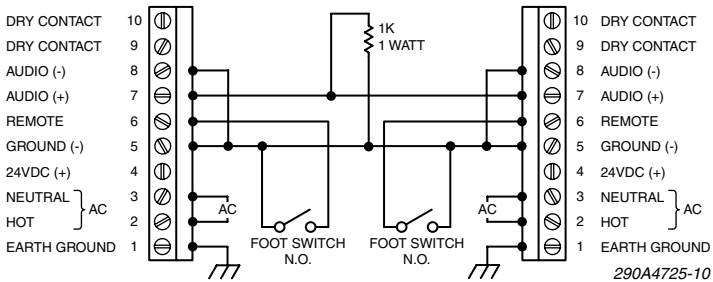
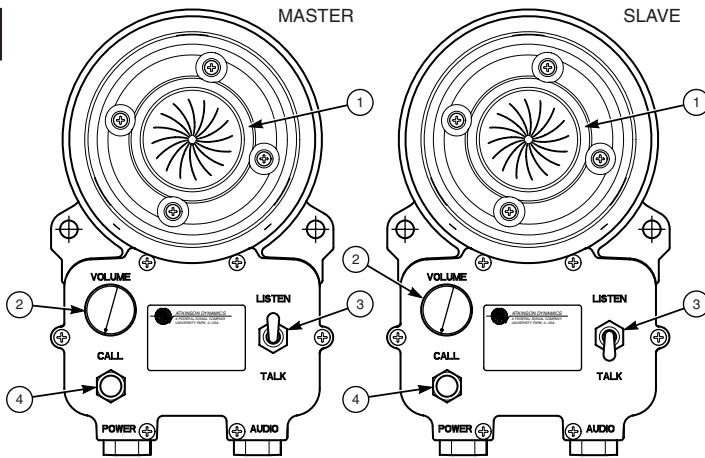

Operating Principle:

- Masters normally listen to slave.
- Slave talks to master hands-free, without having to press a talk switch.
- When any master talks, slave hears. Other masters will hear.
- To talk into master, press talk switch and speak into speaker/microphone. Release talk switch to listen.

NOTES:

1. Speaker/Microphone
2. Off/On/Speaker volume control
3. Press-to-talk Switch
4. "Call" Tone Switch

| <u>Power</u> | <u>Master</u> | <u>Slave</u> |
|--------------|---------------|--------------|
| 120V 50/60Hz | AD-28X-MV | AD-28X-MV |
| 22-30VDC | AD-28X-MV | AD-28X-MV |
| 240V 50/60Hz | AD-28X-MV | AD-28X-MV |

Reminders:

- Before installing remote intercoms, precautions should be taken to prevent feedback between two or more remotes in close proximity and acoustically reflective areas.
- Audio and power cables are not supplied with AD-28X-MV.
- In this installation the Master is constantly broadcasting audio from the Slave. Pushing the listen/talk switch on either unit forces the Slave into the listen mode and the Master into the talk mode. The MAS/SLA jumper J2, located on the P.C. board inside the Slave, must be placed in the SLA mode for this operation. See SLAVE MODE on page 2 and figures 2 and 6.
- Using normally open, simple contact closure foot switches (customer supplied) allows for total hands-free operation of the listen/talk functions.

Operating Principle:

- When one talks, all intercoms will hear.
- To talk to other stations, press the talk/listen switch and speak into the speaker/microphone. Release talk switch to listen.
- Pressing the call button on remote A or B provides a contact closure for an attention-getting auxiliary signaling device, e.g. a strobe light.

NOTES:

1. Speaker/Microphone
2. Off/On/Speaker Volume Control
3. Listen/Talk Switch
4. "Call" Tone Switch
5. Customer-Supplied Auxiliary Signaling Device (e.g., strobe light)

Power

- 12-18VDC
- 120V 50/60Hz
- 22-30VDC
- 240V 50/60Hz

Remote A

-
- AD-28X-MV
- AD-28X-MV
- AD-56-3
- AD-57-3

Remote B

- AD-26-3
- AD-27-3
- AD-56-3
- AD-57-3
- 12/24V Models
- 120/240V Models
- 12/24V Models
- 120/240V Models
- 120/240V Models only

POWER CONNECTIONS (Remote B):

- BLK +DC Power
- HOT
- Common
- Neutral
- Earth Ground

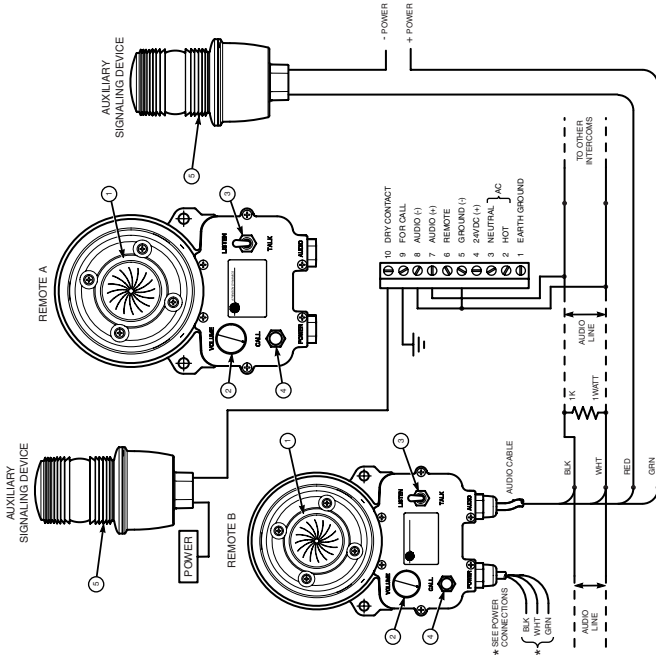

29044725-11

Reminders:

- Before installing remote intercoms, precautions should be taken to prevent feedback between two or more remotes: in close proximity and acoustically reflective areas.
- 16-20 gauge low voltage audio cable. Twisted pair not required.
- Shielded audio cable not required unless operating in high electromagnetic fields. Ground one end of the shield to earth ground.
- Audio and power cables are not supplied with AD-28X-MV.
- The dry contacts can be used to switch an auxiliary audible or visual signaling device when the call button is depressed. The maximum ratings for the dry contacts are 0.5 amps @ 125VAC and 1.25 amps @ 24VDC. This method assures a call is received even when the volume on one of the intercoms is turned all the way down.

Operating Principle:

- Masters normally listen to slave.
- Slave talks to master hands-free, without having to press a talk switch.
- When any master talks, slave hears. Other masters will hear.
- To talk into master, press talk switch and speak into speaker/microphone. Release talk switch to listen.

NOTES:

1. Speaker/Microphone
2. Off/On/Speaker volume control
3. Press-to-talk Switch
4. "Call" Tone Switch
5. Desk Set speaker (microphone is mounted on handset)
6. Desk Set speaker volume control (mounted on back of case)
7. Handset earpiece volume control (mounted on back of case)

| Power | Master A | Master B | Slave |
|--------------|----------|----------|-----------|
| 12-18VDC | AD-26CT | AD-26C | -- |
| 120V 50/60Hz | AD-27CT | AD-27C | AD-28X-MV |
| 22-30VDC | -- | AD-56C | AD-28X-MV |
| 240V 50/60Hz | -- | AD-57C | AD-28X-MV |

POWER CONNECTIONS (MASTER A & B):

| | | |
|-----|--------------|----------------------|
| BLK | +DC Power | 12/24V Models |
| WHT | HOT | 120/240V Models |
| GRN | Common | 12/24V Models |
| | Neutral | 120/240V Models |
| | Earth Ground | 120/240V Models only |

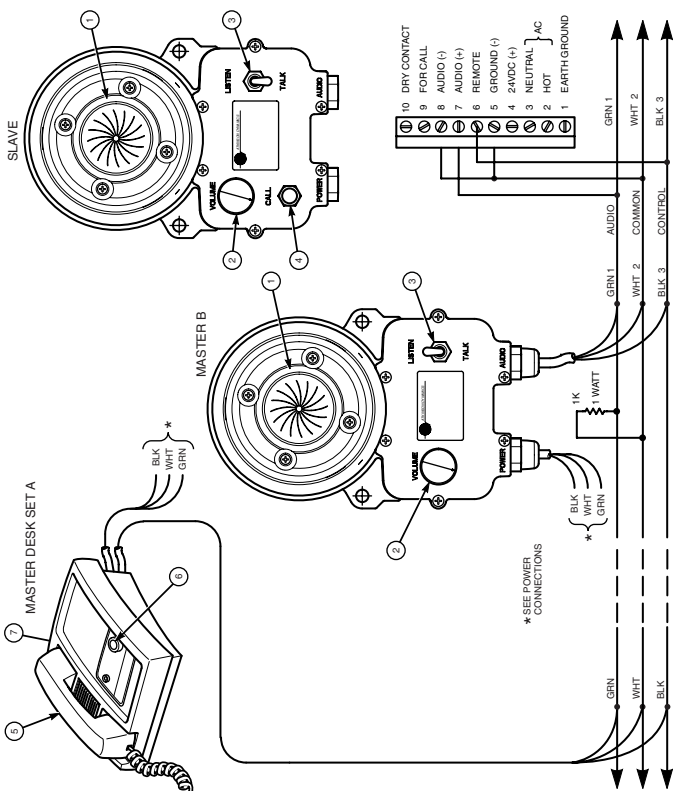

290A4725-12

Reminders:

- Before installing remote intercoms, precautions should be taken to prevent feedback between two or more remotes in close proximity and acoustically reflective areas.
- Audio and power cables are not supplied with AD-28X-MV.
- In this installation the Masters are constantly broadcasting audio from the Slave. Pushing the listen/talk switch on any unit forces the Slave into the listen mode and the Master into the talk mode. The MASS/SLA jumper J2, located on the P.C. Board inside the Slave, must be placed in the SLA mode for this operation. See SLAVE MODE on page 2 and figures 2 and 6.

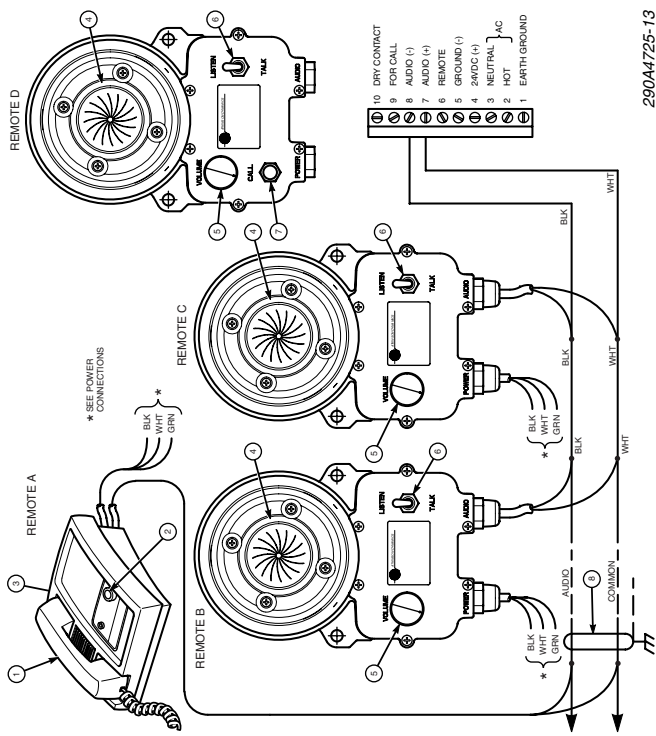

290A4725-13

| POWER | REMOTE A | REMOTES B & C | REMOTE D |
|--------------|----------|---------------|-----------|
| 12VDC | AD-26T | AD-26 | AD-28X-MV |
| 120V 50/60Hz | AD-27T | AD-27 | AD-28X-MV |
| 240V 50/60Hz | AD-57T | AD-57 | AD-28X-MV |
| 22-30VDC | AD-56T | AD-56 | |

POWER CONNECTIONS (Remote A, B, & C):

- BLK +DC POWER
- HOT 12/24V Models
- 120/240V Models
- WHT Common
- 12/24V Models
- Neutral 120/240V Models
- GRN Earth Ground
- 120/240V Models only

NOTES:

1. Desk Set speaker (microphone is mounted on handset)
2. Desk Set speaker volume control
3. Handset earpiece volume control (mounted on back of case)
4. Speaker/Microphone
5. Off/On/Speaker volume control
6. Talk/Listen switch
7. "Call" Tone Switch
8. 3-conductor/16-22gauge cable. Use shielded cable in electrically noisy areas. Ground one end of the shield to "earth" ground. Ground chassis of DC unit to ground.

Operating Principle:

1. When one intercom talks, all of the intercoms will hear.
2. For Remotes B, C, or D to talk to other stations, press the talk/listen switch and speak into the speaker/microphone. Release talk switch to listen.
3. For Remote A to talk to other stations, press PTT-button on handset and talk into handset microphone.

Reminders:

- Before installing remote intercoms, precautions should be taken to prevent feedback between two or more remotes in close proximity and acoustically reflective areas.
- 16-20 gauge low voltage audio cable. Twisted pair not required.
- Shielded audio cable not required unless operating in high electromagnetic fields. Ground one end of the shield to earth ground.
- Audio and power cables are not supplied with AD-28X-MV.

